

MultiPlus-II External Transfer Switch application

Manual

Rev 00 - 07/2024

This manual is also available in HTML5.

This manual is also available in PDF.

Table of Contents

1. Introduction	1
1.1. Advantages	1
1.2. Compatibility	1
1.3. Hardware requirements	1
2. Functionality	2
2.1. Single line diagram	2
3. Installation	3
3.1. AC voltage measurement	3
3.2. Current transformer	3
3.3. Ground relay	4
3.4. External transfer switch	4
4. Configuration	6
4.1. Upgrade to S99 VE.Bus firmware	6
4.2. VE.Bus System configuration	6
4.3. MultiPlus-II configuration	7
4.4. Venus OS version	8
5. Troubleshooting	9
6. Wiring diagram	10

1. Introduction

This manual provides instructions for installing and configuring a system using an external transfer switch (contactor) instead of the built-in relays of the MultiPlus-II.

This application significantly enhances the versatility, cost-effectiveness, and reliability of larger systems, particularly those of 60kVA and above.

Note that this setup is intended solely for generator-based systems and is not certified for use with grid-tied systems.

1.1. Advantages

- **Reduce installation time and costs:** This significantly reduces costs and installation time, especially for large systems with multiple units in parallel. It removes the need to wire each unit's AC input and output terminals.
- **Reduce equipment costs:** Combining MultiPlus-II 8, 10, or 15kVA units with an external transfer switch lifts their "no parallel" restriction. Otherwise, the more expensive Quattro 8, 10, or 15kVA units would have been required.
- **Flexible installation:** MultiPlus-II units and batteries can be placed up to 20 meters from the main distribution board without running power wiring back and forth.
- **No Bypass Switch Required:** Eliminates the need for a separate bypass switch.

1.2. Compatibility

This application supports all MultiPlus-II models rated at 5000VA and above.

Key specifications:

- **AC transfer rating:** 100 or 400A.
- **Unit limit:** Up to 12 MultiPlus-II units, with a maximum of 4 per phase.
- **System size:** Up to 180kVA.
- **AC input:** Supports only one AC input source.
- **AC input type:** Generator AC input only, not for grid connection.
- **Firmware:** Requires application-specific VE.Bus firmware, version S99.
- **Hardware:** Additional hardware is required; refer to the [Hardware requirements \[1\]](#) list.

1.3. Hardware requirements

- **External transfer switch:** Schneider LC1G3304 TeSys Giga, 4-pole (4NO), AC-1 <=440V 440A high current four-pole contactor.
- **Ground relay:** High current single-pole relay.
- **Ground help relay:** Low-power 230V relay with a 24V coil, enabling the MultiPlus-II low-power control signal to drive the high-power ground relay.
- **Victron Current Transformer(s):** One per phase, rated at 100 or 400A, for accurate current measurement and power management.
- **Four-pole circuit breakers and RCD:** For circuit protection.
- **Electrical wiring:** Refer to the [Installation \[3\]](#) chapter for detailed instructions.

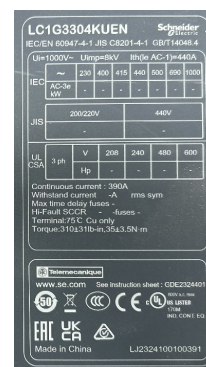

Schneider
LC1G3304KUEN
contactor

2. Functionality

The external transfer switch replaces the internal AC transfer switch of each individual MultiPlus-II unit in the system. The system operates almost identically to one using the internal AC transfer switches.

Features such as UPS functionality, AC input current limit, PowerControl, and PowerAssist remain active.

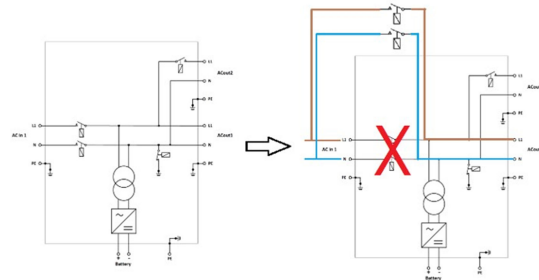

2.1. Single line diagram

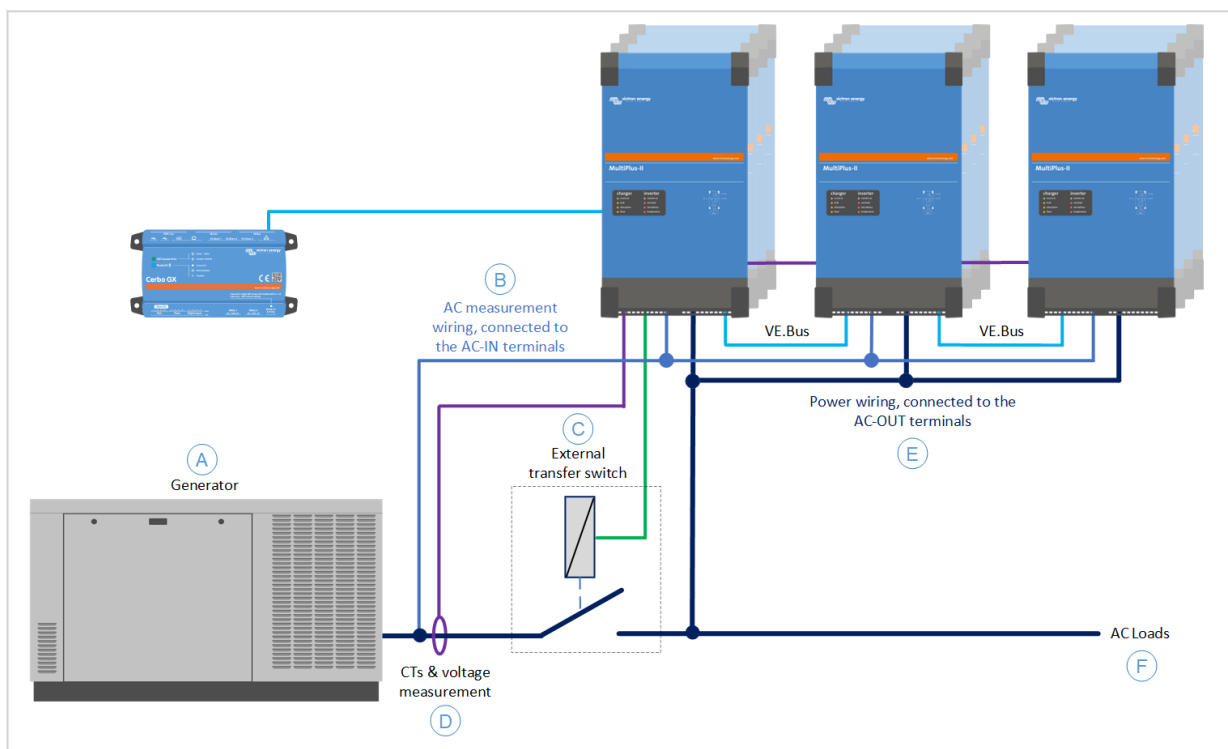

A	Generator
B	AC voltage measurement wiring, connected to the MultiPlus-II AC-IN terminals
C	External transfer switch
D	Current transformers (CTs) and AC voltage measurement wires
E	Power wiring connected to the MultiPlus-II AC-OUT terminals
F	AC loads

3. Installation

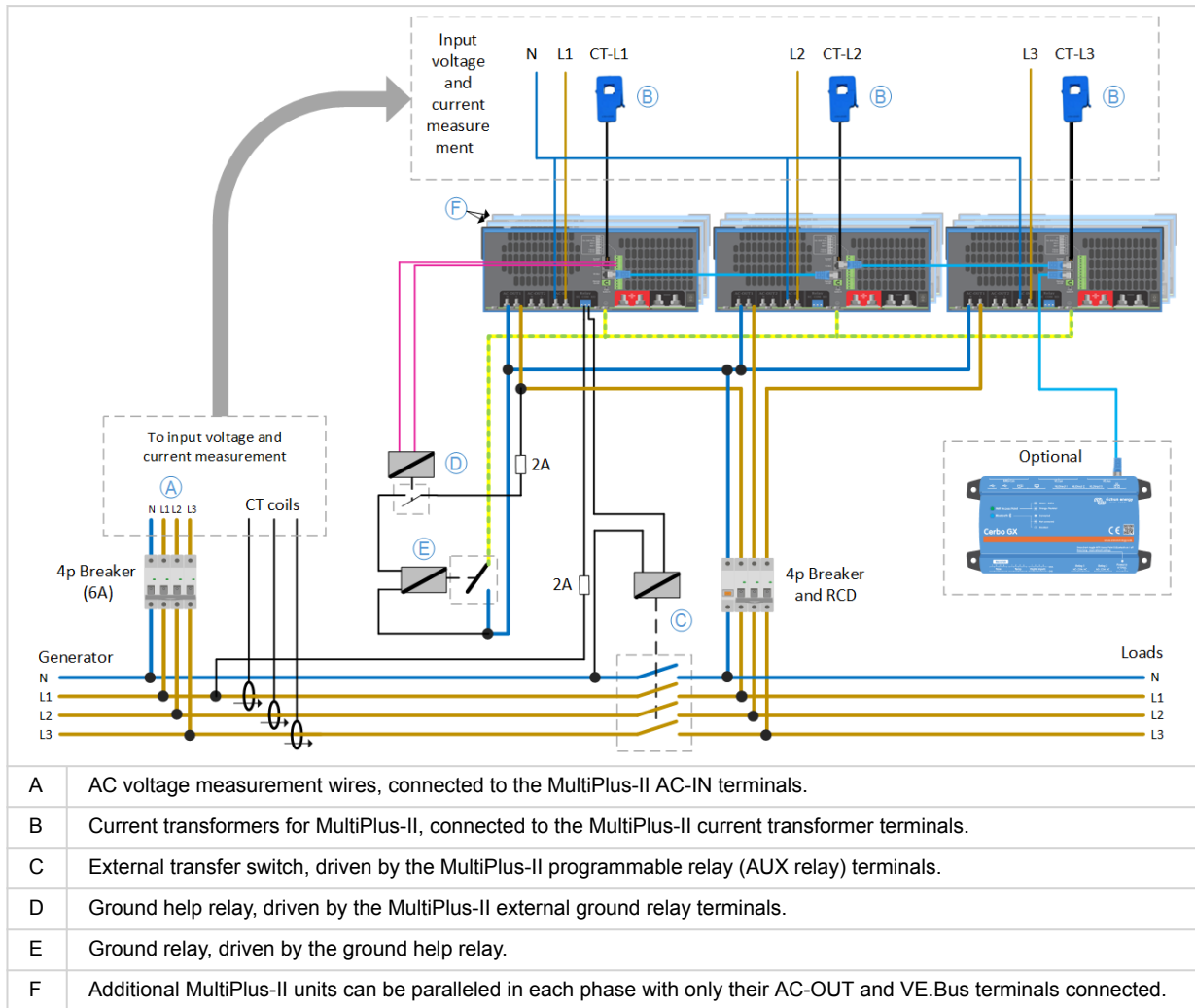

For the full-size diagram, see the [Wiring diagram \[10\]](#) section.



Parallel and multiphase systems are complex. We do not support or recommend untrained or inexperienced installers working on these systems.

Before the system's initial power-up, double-check all wiring. Wiring mistakes can damage the MultiPlus-II units.

3.1. AC voltage measurement

The MultiPlus-II's AC input functions as a measuring input. Since the internal back-feed relay is not used, the wires can be relatively thin, 1.5mm² wires are sufficient.

Connection procedure:

1. Connect the AC-IN terminals of MultiPlus-II to the generator AC supply.
2. For paralleled units, connect only the master unit (of each phase) to the AC-IN terminal and leave the slave units' AC-IN terminals unconnected.
3. Use a 6A four-pole circuit breaker to fuse the line and neutral wires.

3.2. Current transformer

The current transformers for each phase (L1, L2, and L3) are connected to the "Current Sense" inputs on the respective phase master MultiPlus-II units:

Connection procedure:

1. Remove the wire bridge between the INT and COM terminals.
2. Connect the red sensor wire to the EXT terminal and the white sensor wire to the COM terminal.
3. Ensure the wire direction through the current sensor follows the arrow pointing from the generator to the MultiPlus-II.

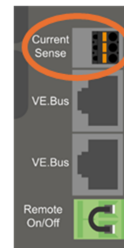
**Important notes:**

- Avoid routing current sensor wiring parallel and close to AC power wiring, signal wiring or VE.Bus wiring to prevent signal interference.
- The 400A current transformer has a reduced current sensing resolution, especially at low currents.

Compatible current transformers:

- **CRT12XXXXXX**: Current Transformer 100A:50mA for MultiPlus-II Wire-end (available in 1.5 and 20m cable length).
- **CTR140050100**: Current Transformer 400A:50mA for MultiPlus-II (10m) Wire-end (the current sensor wiring can be extended up to 20m using 0.75mm² wire).
- **CRT11XXXXXX**: Current Transformer 100A:50mA for MultiPlus-II Jack connector (for older MultiPlus-II units, available in 1.5 or 20m length).

For more information, see: <https://www.victronenergy.com/meters-and-sensors/current-transformer-for-multiplus-ii>.

3.3. Ground relay

The ground relay drive signal is supplied by the MultiPlus-II "Ext GND Relay" terminals of the L1 phase master unit via a help relay.

Since the "Ext GND Relay" output signal is limited to 24V / 200mA, a help relay with a 24V coil must be used to switch the actual ground relay.

The ground relay rating must match the total inverter power of the system.

Connection procedure:

1. Connect the help relay coil terminals to the MultiPlus-II "Ext. GND Relay" terminals.
2. Connect the help relay power terminals to L1 MultiPlus AC-OUT L terminal and one of the Ground relay coil terminals. Fuse this wire with a 2A fuse.
3. Connect the remaining ground relay coil terminal to the L1 MultiPlus-II AC-OUT N terminal.
4. Connect the ground relay power terminals between The MultiPlus-II GND and AC-OUT N terminals.

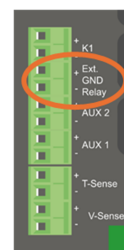

3.4. External transfer switch

Use a Schneider LC1G3304 TeSys Giga, 4-pole (4NO), AC-1 <=440V 440A contactor. **Do not** use a different contactor, as closing and opening times vary between brands and models.

Since inverter current flows through the AC outputs of the MultiPlus-II units, ensure the external transfer contactor wiring is appropriately sized and symmetrical.

Connection procedure:

1. Connect the contactor coil directly to the NO and COM terminals of the MultiPlus-II "AUX RELAY" terminals of the L1 phase master unit. Fuse this wire with a 2A fuse.
2. Connect one side of the contactor power terminals to the generator.
3. Connect the other side of the contactor power terminals to the AC-OUT terminals or the MultiPlus-II units and the AC loads.
4. Protect the AC output wiring with a circuit breaker suitable for the expected load and wire gauge. Fuse both line and neutral wiring.

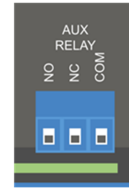

4. Configuration

4.1. Upgrade to S99 VE.Bus firmware

The MultiPlus-II units require application-specific VE.Bus firmware, identified by the “.S99” subversion number.

Upgrade procedure:

1. Download the xxxyy.S99.vff file from <https://professional.victronenergy.com/>
2. Install the firmware using VEFlash, the VictronConnect app, or the VRM Portal.
3. Ensure you select the xxxyy.S99.vff file during the firmware upgrade.
4. Repeat the process for all MultiPlus-II units.



CAUTION: Never use MultiPlus-II unit with standard firmware in an "External transfer switch" application. This will cause the system to connect to the AC input and likely trigger the current protection on that measurement-only circuit.

4.2. VE.Bus System configuration

Use the "VE.Bus System Configurator" to set up the system.

Configuration procedure

1. Configure all phase masters in AC input group 1.
2. Configure all slaves in AC Input Group 2.

Refer to the following screenshots.

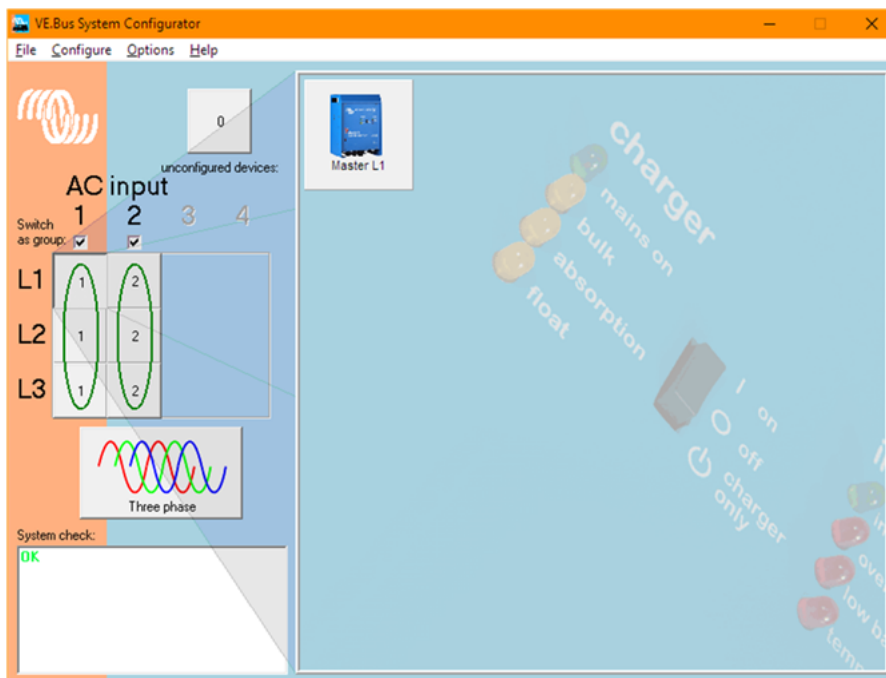

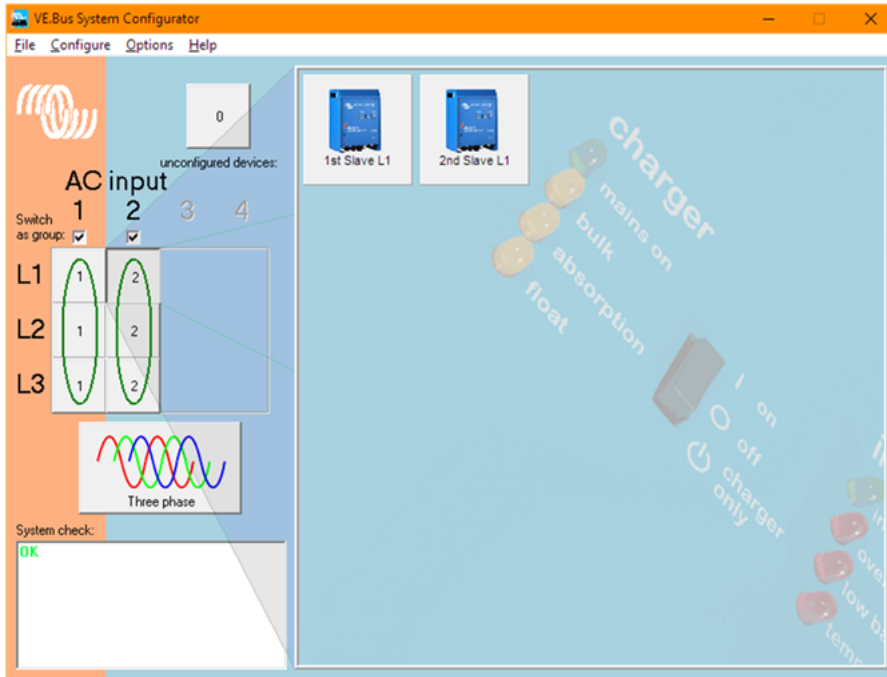

4.3. MultiPlus-II configuration

Use "VEConfigure" to configure each MultiPlus-II unit.

Configuration procedure:

1. Ensure the "S99" firmware version is installed
2. Navigate to the "General" tab.
3. For all phase master units, set the "Current sensor rating" to 100 or 400A, matching the current sensor's current rating.
4. For all slave units, set the "Current sensor rating" to 100A, regardless of the current sensor's current rating.
5. Navigate to the "Grid" tab.
6. For all units, set the "Country/grid code standard" to "None".

Refer to the following screenshot.

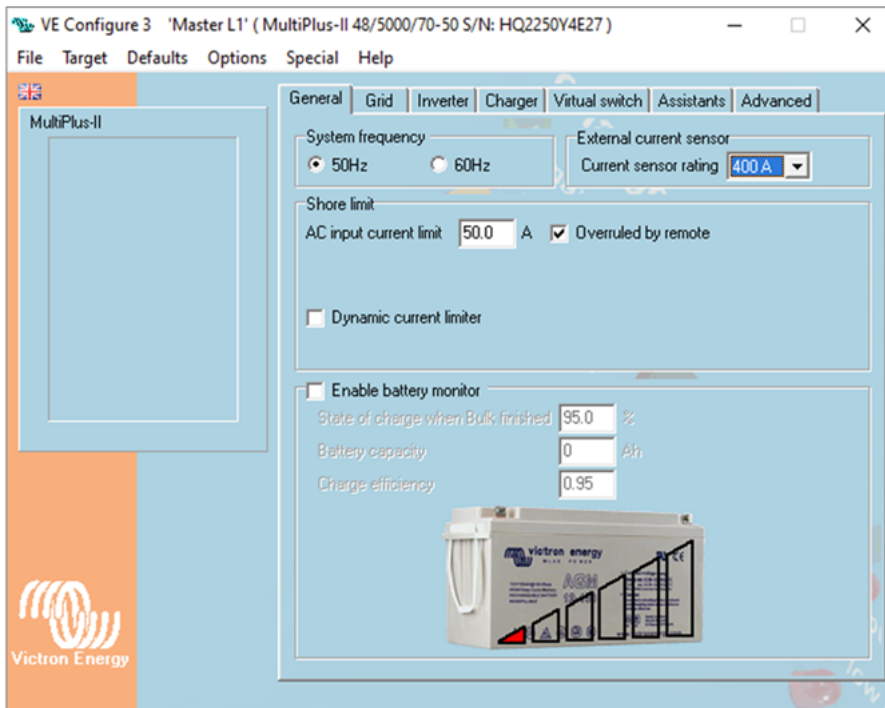

4.4. Venus OS version

If a GX device is used, it should be updated to Venus OS version 3.33 or later.

5. Troubleshooting

If the system exhibits strange behaviour, check the following:

1. **Current sensor orientation:** Ensure the current transformers are oriented correctly. The arrow on the CT should point from the generator to the contactor, matching the direction indicated in the [Wiring diagram \[10\]](#).
2. **Current sensor connections:** Verify that the current sensors are connected to the correct units: L1 to the L1 unit, L2 to the L2 unit, and so on.
3. **Wiring placement:** Ensure the current sensor wires are not routed too close to AC or signal wires.

Known issues:

- **VRM kWh counters:** The VRM kWh counters may display incorrect readings. This will be addressed in an upcoming version of Venus OS.
- **VictronConnect App:** The VictronConnect app cannot be used for system configuration and current sensor settings. Use VEConfigure 3 and VE.Bus System Configurator software instead.

